

SUGGESTED RULES FOR PA 4-H REINING CLASS

(for use at county or district shows)

GENERAL:

To rein a horse is not only to guide him, but also to control his every movement. The best reined horse should be willingly guided or controlled with little or no apparent resistance and dictated to completely. Any movement on his own must be considered a lack of control. All deviations from the exact written pattern must be considered a lack of or temporary loss of control, and therefore faulted according to severity of deviation. After deducting all faults against execution of the pattern and the horse's overall performance, credit will be given for smoothness, finesse, attitude, quickness and authority in performing the various maneuvers while using controlled speed which raises the difficulty level and makes the horse more exciting and pleasing to watch.

SCORING:

1. Scoring will be on a 0 to Infinity basis, with 70 denoting an average performance. Individual maneuvers are scored in 1/2 point increments from a low of -1 1/2 to a high of +1 1/2 with a score of 0 denoting a maneuver that is correct with no degree of difficulty.

The following will result in NO SCORE.

1. Use of illegal equipment (equipment requirements are the same as the Western division. Protective leg gear on the horse is permitted, such as splint boots, skid boots.)
2. Use of whips or bats is prohibited.
3. Disrespect or misconduct by the exhibitor.
4. Abuse of an animal in the show arena and/or evidence that an act of Abuse has occurred. The judge may excuse a horse at any time while in the arena for unsafe conditions or improper exhibition pertaining to the horse and/or rider.

The rider may untangle or straighten excess rein, where excess rein may prevent the rider from continuing the pattern, where the excess can be adjusted without affecting the performance of the horse, during hesitations, or when stopped and settling the horse; the rider's free hand may be used to hold a romal in the normal fashion.

The following will result in a score of 0.

1. Use of more than index or first finger between reins
2. Use of two hands (exception when using a snaffle bit or hackamore)
3. Improper use of romal (use of the free hand while holding the romal to alter the tension or length of the reins from the bridle to the reining hand is considered to be the use of two hands, and will result in a 0 score – the romal may not be used as a whip or bat at any time)
4. Failure to complete the pattern as written
5. Inclusion of maneuvers not specified, including, but not limited to
 - a. backing more than 2 strides
 - b. turning more than 90 degrees
6. Equipment failure that delays completion of pattern; including dropping a rein that contacts the ground while the horse is in motion
7. Balking or refusal of command where pattern is delayed
8. Running away or failing to guide where it becomes impossible to discern whether the entry is on pattern.
9. Jogging in excess of one-half circle or one-half the length of the arena
10. Overspins of more than 1/4 turn
11. Fall to the ground of horse or ride

The following will result in a reduction of 5 points:

1. Spurring in front of cinch
2. Use of either hand to instill fear or praise
3. Holding saddle with either hand
4. Blatant disobediences including kicking, biting, bucking, rearing, and striking.
- 5.

The following will result in a reduction of 2 points:

1. Breaking gait
2. Freezing up in spins or rollbacks
3. On walk-in patterns, failure to stop or walk before executing a canter departure
4. On run-in patterns, failure to be in a canter prior to the first marker
5. If a horse does not completely pass the specified marker before initiating a stop position

Each time a horse is out of lead, a judge is required to deduct 1 point. The penalty for being out of lead is accumulative and the judge will deduct 1 penalty point for each quarter of the circumference of a circle or any part thereof that a horse is out of lead. A judge is required to penalize a horse 1/2 point for a delayed change of lead by one stride.

Deduction of 1/2 point for starting a circle at a jog or exiting rollbacks at a jog up to two strides. Jogging beyond two strides, but less than 1/2 circle or 1/2 the length of the arena, is a deduction of 2 points.

Deduction of 1/2 point for over or under spinning up to 1/8 of a turn; deduct 1 point for over or under spinning from 1/8 to 1/4 turn.

A 1/2 point penalty deduction will be given for failure to remain a minimum of 20 feet from the wall or fence when approaching a stop or rollback.

In patterns requiring a run-around, failure to be on the correct lead when rounding the end of the arena will be penalized as follows: for 1/2 the turn or less, 1 point; for more than 1/2 turn, 2 points.

Faults against the horse to be scored accordingly, but not to cause disqualification:

1. Opening mouth excessively when wearing a bit
2. Excessive jawing, opening mouth or head raising on stop
3. Lack of smooth, straight stop on haunches, bouncing or sideways stop
4. Refusing to change leads
5. Anticipating signals
6. Stumbling
7. Backing Sideways
8. Knocking over markers

Faults against the rider to be scored accordingly, but not to cause disqualification

1. Losing stirrup
2. Failure to run circles or figure eights within the markers is not considered a fault depending on arena conditions and size; however, failure to go beyond markers on rollbacks and stops is considered a fault.

PATTERNS

1. The following patterns are to be worked as stated, not as drawn. The drawn pattern is just to give the general idea of what the pattern will look like In the arena.
2. Markers will be placed on the wall or fence of the arena as follows:
 - a. at the center of the arena
 - b. at least 50' from each end wall
3. Where designated in the pattern for stops to be beyond a marker, the horse should begin his stop after he passes the specified marker.
4. Each pattern is drawn so that the bottom of the page represents the end of the arena entered by exhibitors and must be run as such. In the event that an arena has only one gate and it is in the exact middle of the side, that side shall represent the right side of the page the pattern is drawn on.
5. All horses will be judged immediately upon entering the arena and judging will cease after the last maneuver. Any fault incurred prior to the commencement of a pattern will be scored according to the rules for judging.

Pattern 1

1. Run at speed to the far end of the arena past the end marker and do a left rollback - no hesitation.
2. Run to the opposite end of the arena past the end marker and do a right rollback - no hesitation.
3. Run past the center mark and do a sliding stop. Back up to center of the arena or at least ten feet. Hesitate.
4. Complete four spins to the right.
5. Complete four and one-quarter spins to the left so that horse is facing left wall or fence. Hesitate.
6. Beginning on the left lead, complete three circles to the left: the first circle large and fast; the second circle small and slow; the third circle large and fast. Change leads at the center of the arena.
7. Complete three circles to the right: the first circle large and fast; the second circle small and slow; the third circle large and fast. Change leads at the center of the arena.
8. Begin a large fast circle to the left but do not close this circle. Run straight up the right side of the arena past the center marker and do a sliding stop at least twenty feet from the wall or fence. Hesitate to demonstrate the completion of the pattern.

* Rider may be asked to dismount and drop the bridle for inspection.

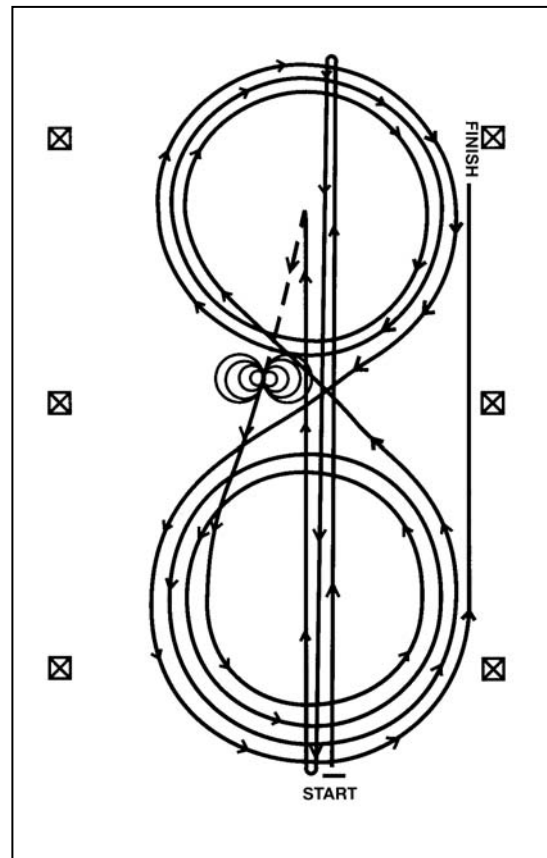

Pattern 2

**Beginning at the center of the arena facing the left wall or wall or fence.

1. Beginning on the right lead, complete three circles to the right: the first circle small and slow; the next two circles large and fast. Change leads at the center of the arena.
2. Complete three circles to the left: the first circle small and slow; the next two circles large and fast. Change leads at the center of the arena.
3. Continue around previous circle to the right. At the top of the circle, run down the middle to the far end of the arena past the end marker and do a right rollback - no hesitation.
4. Run up the middle to the opposite end of the arena past the end marker and do a left rollback - no hesitation.
5. Run past the center marker and do a sliding stop. Back up to the center of the arena or at least ten feet. Hesitate.
6. Complete four spins to the right.
7. Complete four spins to the left. Hesitate to demonstration of the pattern.

* Rider may be asked to dismount and drop the bridle for inspection.

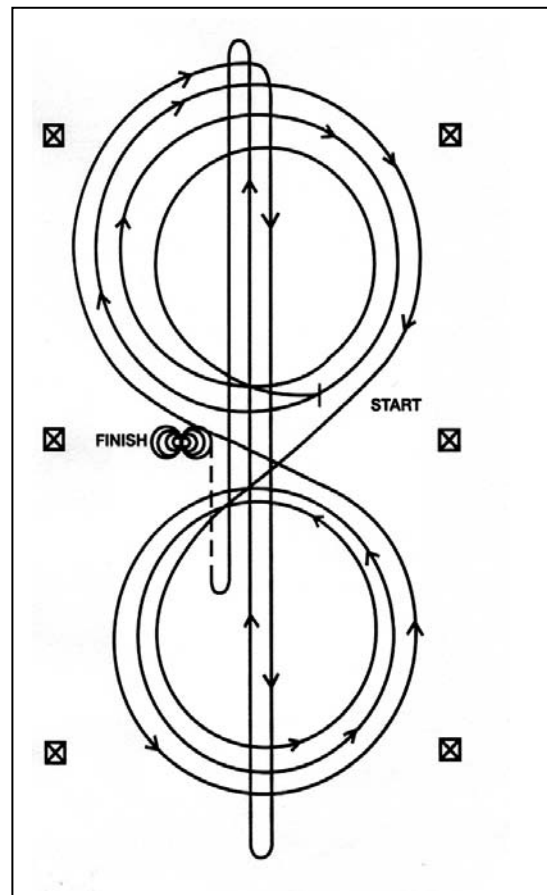

Pattern 3

1. Starting at the center marker make a large fast circle to right on the right lead.
2. Draw the circle down to a small circle until you reach the center marker; stop.
3. Do a double spin to the inside of the small circle at the center marker; at end of spins horse should be facing the left wall, slight hesitation.
4. Begin on left lead and make a large fast circle.
5. Then a small circle, again drawing it down to the center of the arena, stop, no hesitation on these stops.
6. Do a double spin to the inside of the circle, slight hesitation, horse to be facing left wall.
7. Take a right lead and make a fast figure eight over the large circles, close the eight, and change leads.
8. Begin a large fast circle to the right but do not close this circle. Run down the right side of the arena past the marker and do a left roll back at least 20 feet (6 meters) from the wall or fence – no hesitation.
9. Continue back around the previous circle but do not close this circle. Run down the left side of the arena past the center and do a right roll back at least 20 feet (6 meters) from the wall or fence – no hesitation.
10. Continue back around previous circle but do not close this circle. Run down the right side of the arena past the center marker and do a sliding stop at least 20 feet (6 meters) from the wall or fence. Back up at least 10 feet (3 meters). Hesitate to show completion of pattern.

* Rider may be asked to dismount and drop the bridle for inspection.

